

LAMB COMPONENTS

CARBON BRAKE ROTOR & PAD SPECIFICATIONS

FRONT 10.0" CARBON ROTOR & PADS (1620 CALIPER)

ROTOR:

NEW - .450"
MINIMUM - .350"

INNER PAD:

NEW - .650"
MINIMUM - .525"

OUTER PAD:

NEW - .425"
MINIMUM - .300"

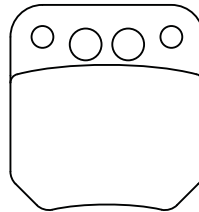

732 & 733

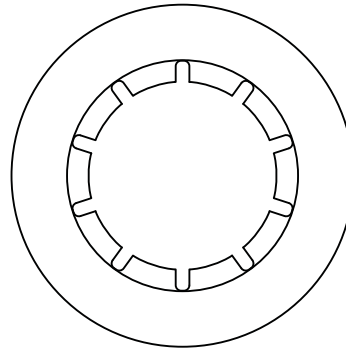

1300-B

REAR 11.5" CARBON ROTOR & PADS (1602 CALIPER)

ROTOR:

NEW - .450"
MINIMUM - .350"

INNER & OUTER PADS:

NEW - .500"
MINIMUM - .350"

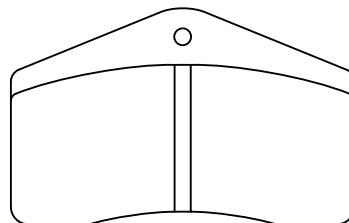

718B

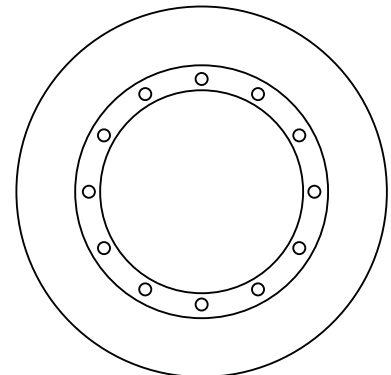

1301-B

FRONT & REAR 11" PADS (1608 CALIPER)

INNER & OUTER PADS:

NEW - .388"
MINIMUM - .225"

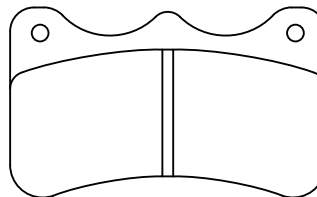

718A

- Front & rear rotors should be resurfaced at mid life - .410" approx. thickness. This will give better performance and extend the useful life.
- We surface the rotor at no charge if you are purchasing replacement pads.
- The front only requires new inner pads. We will make new outer pads from your worn out inner pads.
- Do not attempt to surface yourself as it requires very special fixturing and diamond tooling.